



HILOMAST LLC

BROADCAST MASTS

Specification

- 25' Extended Height
- 6' Retracted Height
- 6 Sections
- 3.5" Diameter Top Section
- 150 lbs Vertical Head load
- Basic Mast Weight of 110 lbs
- Base Diameter of 6"
- Anodized Finish
- Drain Holes
- Available with Roof Bearing kit
- 91 mph Unguyed Wind Speed with 3.2 Sq ft Surface Area

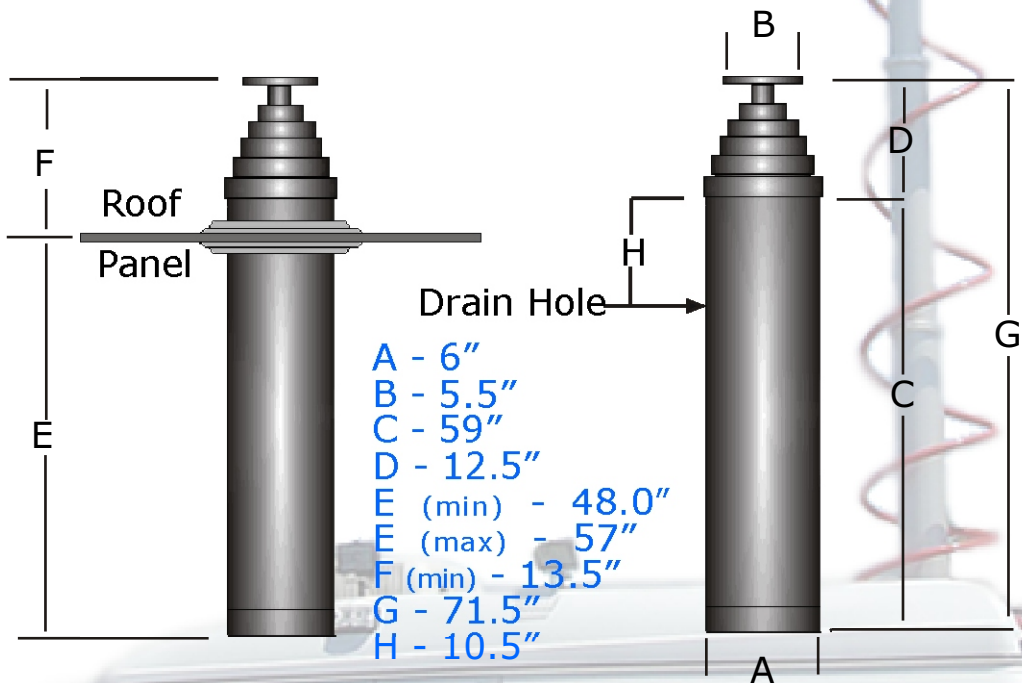
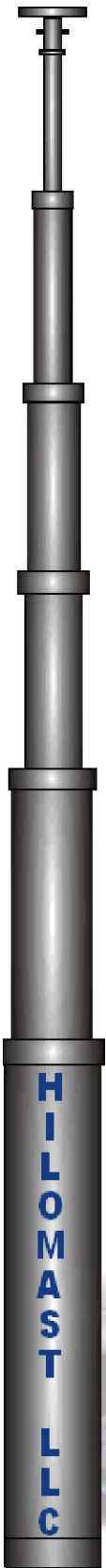

Benefits & Advantages

- No Metal-to-Metal Contact, Reduces Wear & Failure Rate
- Drawn Pneumatic Quality Tube, Extends Seal Life
- Interchangeable With Competitors Product
- Split Roof Bearing Design, for Ease Of Fitting
- USA Service Centers Offer Local Support
- Regular Delivery from Stock
- One Piece Molded Seal for Improved Performance
- Reduced Frequency and Low cost of Service & Maintenance

BR25

Spec Sheet

Hilomast LLC

402 Chairman Court
 Debarry FL32713 USA
 Tel: +1 (386) 668-6784
 Fax: +1 (386) 668-6794
 Email: sales@hilomast.com
 Web: www.hilomast.com